

UNIT CODE	DESCRIPTION
PS-RSP 750-24	750 Watt 24 Volt, Single Output Power Supply with PFC plus Voltage & Current Trim Functions

SPECIFICATIONS		
Input	Output	Agency Approvals
Universal 90 ~ 264VAC	+24VDC @ 0 ~ 31.3A	

Features at a Glance:

- Universal AC Input for Worldwide Use
- AC Input Active Surge Current Limiting
- Output Voltage & Current can be Independantly Trimmed between 40-110% via 2-5.5VDC external control signal
- Active PFC (PF>0.97) complys with EN61000-3-2
- Built-in: 12V/0.1A Auxiliary output (remote control); Remote ON-OFF control; Remote sense function
- Protections: Short circuit / Overload / Over voltage / Over temperature and Fan Alarm
- Forced air cooling by DC fan with speed control
- DC OK alarm signal output (TTL signal)
- Working Temp. Range: -30°C~+70°C (-22~158°F)
- Safety Standards: UL60950-1, TUV EN60950-1
- EMC: EN61204-3, heavy Industry level, criteria A
- See following pages for complete EMC details
- Certificates: UL, CUL, TUV, CB and CE
- MBTF: 120.8K hours min. *MIL-HDBK-217F (25°C)*
- Case: 212A
- Weight: 3.61 lbs. (1.64 Kgs)
- Dimensions: 9.8" L x 5.0" W x 1.6" H
250L x 127W x 41H mm
- 3 year warranty



The PS-RSP 750 Series are 750 Watt, 1U (40mm) low profile, enclosed type, switching power supplies with universal AC input, active PFC (PF>0.97) and both voltage and current trim functions.

Standard features: Voltage & Current output trim range 40%~110% so are ideal in charging systems or burn-in equipment that may require wide ranging adjustments of output voltage and/or output current; High power density of 9.4 W/in³; Short circuit, Overload, Over Voltage and Over Temperature protection. Circuits include built-in 12V/0.1A auxiliary output for remote control; Remote ON-OFF control and Remote sense; 100% output from -30~+50°C (derated operation up to +70°C).

Ideal for industrial and military use. Typical applications include general industrial control systems, telecom, data storage, instrumentation, factory automation, laser-carving machines, IC testing equipment, battery charging or any application where space is limited and moderate efficiency is required.

[Click for more information](#)

Pricing:	1 +	\$ 319.95
	10 +	289.50
	25 +	265.00

toll-free 1-866-665-5434 (603) 888-2467 power@electracool.com

Specifications

OUTPUT

DC VOLTAGE	24V
RATED CURRENT	31.3A
CURRENT RANGE	0 ~ 31.3A
RATED POWER	751.2W
RIPPLE & NOISE (max.) <i>Note.2</i>	150mVp-p
VOLTAGE ADJ. RANGE	20 ~ 26.4V
VOLTAGE TOLERANCE <i>Note.3</i>	±1.0%
LINE REGULATION	±0.5%
LOAD REGULATION	±0.5%
SETUP, RISE TIME	1000ms, 50ms at full load
HOLD UP TIME (Typ.)	16m/230VAC 16ms/115VAC at full load

INPUT

VOLTAGE RANGE <i>Note.4</i>	90 ~ 264VAC	127 ~ 370VDC
FREQUENCY RANGE	47 ~ 63Hz	
POWER FACTOR (Typ.)	PF 0.97/230VAC	PF 0.98/115VAC at full load
EFFICIENCY (Typ.)	90.5%	
AC CURRENT (Typ.)	5A: 5.6A/115VAC	2.8A/230VAC
INRUSH CURRENT (Typ.)	25A/115VAC	40A/230VAC
LEAKAGE CURRENT	<2mA / 240VAC	

PROTECTION

OVERLOAD	105 ~ 125% rated output power. Protection type: Constant current limiting, recovers automatically after fault is removed
OVER VOLTAGE	27.6 ~ 32.4V Protection type: Shut down o/p voltage, re-power on to recover
OVER TEMPERATURE	85°C ± 5°C (TSW2) detected on heatsink of O/P diode; 80°C ± 5°C (TSW1) detected on heatsink of power transistor. Shut down o/p voltage, recovers automatically after temperature goes down.

FUNCTION

AUXILIARY POWER(AUX)	12V @ 0.1A ; tolerance : 10%
REMOTE ON/OFF CNTRL <i>Note.6</i>	Power on : short between on/off(pin13) & 12V-AUX(pin14) on CN50 Power off : open between on/off(pin13) & 12-AUX(pin14) on CN50
DC OK SIGNAL	The TTL signal out, PSU turn on = 0 ~ 1V ; PSU turn off = 3.3 ~ 5.6V
OUTPUT VOLTAGE TRIM <i>Note.6</i>	Adjustment of output voltage is between 40 ~ 110% by 2 ~ 5.5VDC external control signal
OUTPUT CURRENT TRIM	Adjustment of output current is possible between 40 ~ 110% by 2 ~ 5.5VDC external control signal

ENVIROMENT

WORKING TEMP.	-30°C ~ +70°C (Refer to the following "Derating Curve")
WORKING HUMIDITY	20 ~ 90% RH non-condensing
STORAGE TEMP., HUMIDITY	-40°C ~ +85°C, 10 ~ 95% RH
TEMP. COEFFICIENT	±0.03%/°C (0 ~ 50°C)
VIBRATION	10 ~ 500Hz, 2G 10min./1cycle, 60min. each along X, Y, Z axes

SAFETY & EMC *(Note 5)*

SAFETY STANDARDS	UL60950-1, TUV EN60950-1 approved
WITHSTAND VOLTAGE	I/P-O/P:3KVAC I/P-FG:2KVAC O/P-FG:0.5KVAC
ISOLATION RESISTANCE	I/P-O/P, I/P-FG, O/P-FG:100M Ohms / 500VDC / 25°C/ 70% RH
EMC EMISSION	Compliance to EN55022 (CISPR22), EN61000-3-2,-3
EMC IMMUNITY	Compliance to EN61000-4-2,3,4,5,6,8,11, EN55024, EN61000-6-2, EN61204-3, heavy industry level, criteria A

toll-free 1-866-665-5434 (603) 888-2467 power@electracool.com

OTHER

MTBF
DIMENSIONS
PACKING

120.8K hrs min. MIL-HDBK-217F (25 °C)
250x127x41mm (L*W*H)
1.64Kg; 6pcs/10.8Kg/1.1CUFT

- NOTES:** 1. All parameters NOT specifically mentioned are measured at 230VAC input, rated load and ambient temperature of 25°C.
2. Ripple & noise are measured at 20MHz of bandwidth by using a 12" twisted pair-wire terminated with a 0.1uf & 47uf parallel capacitor.
3. Tolerance: includes set up tolerance, line regulation and load regulation.
4. Derating will be required when operating under certain low input voltages. Please see the following Derating Curve.
5. The power supply is considered a component which will be installed into a final piece of equipment. That final equipment must be re-confirmed as still meeting EMC directives. For guidance on how to perform these EMC tests, please Google "EMI testing of component power supplies."
6. The power supply unit will have no output if the shorting connector (accessory comes along with the PSU) is not assembled. It contains three shorting wires : one is from ON/OFF (pin13) to 12V-AUX (pin14), two is from PV(pin5) to PS (pin6) and the other is from PC (pin7) to PO (pin8).

Mechanical Specification

Case No.212A Unit:mm

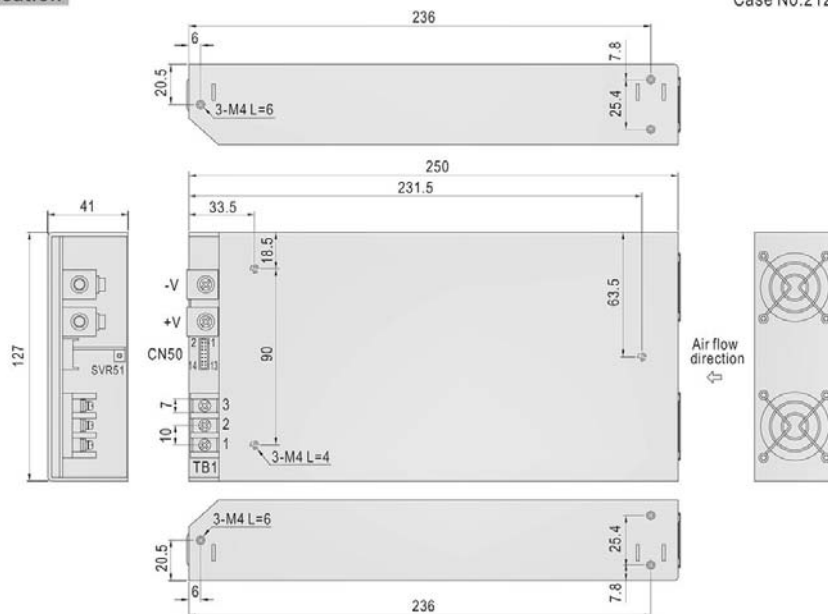

AC Input Terminal

Pin No.	Assignment
1	AC/N
2	AC/L
3	FG

Control Pin No. Assignment (CN50) : HRS DF11-14DP-2DS or equivalent

Pin No.	Assignment	Pin No.	Assignment	Pin No.	Assignment	Mating Housing	Terminal
1	+S	6	PS	12	G-AUX	HRS DF11-14DS or equivalent	HRS DF11-14SC or equivalent
2	+VS	7	PC	13	ON/OFF		
3	-S	8	PO	14	12V-AUX		
4	-VS	9	DC-OK				
5	PV	10,11	GND				

Block Diagram

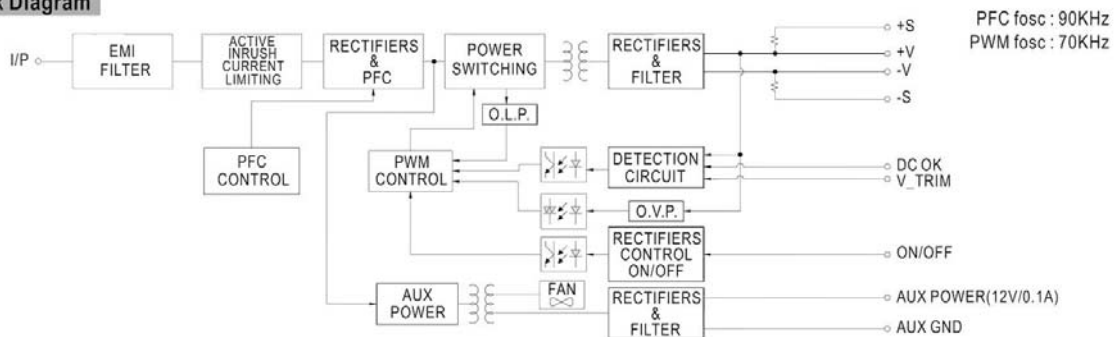

toll-free 1-866-665-5434 (603) 888-2467 power@electracool.com

Derating Curve

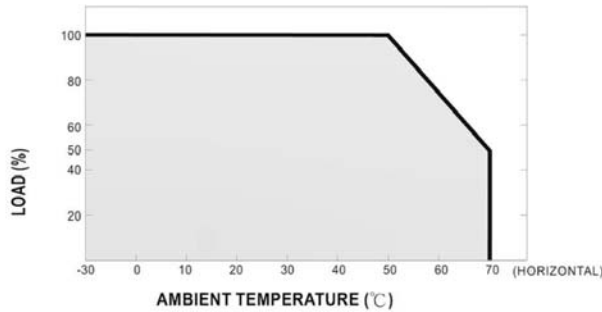

Static Characteristics

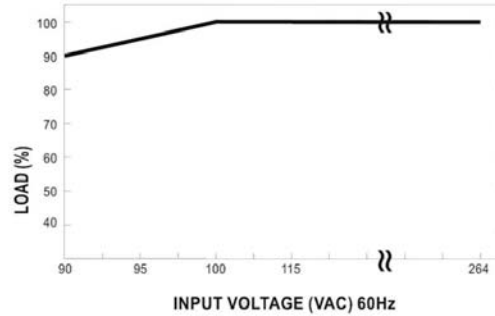

Function Description of CN50

Pin No.	Function	Description
1	+S	Positive sensing. The +S signal should be connected to the positive terminal of the load. The +S and -S leads should be twisted in pair to minimize noise pick-up effect. The maximum line drop compensation is 0.5V.
2	+VS	+V Signal. The +VS should be connected to the +S to reduce the noise when "output voltage TRIM" function is in use.
3	-S	Negative sensing. The -S signal should be connected to the negative terminal of the load. The -S and +S leads should be twisted in pair to minimize noise pick-up effect. The maximum line drop compensation is 0.5V.
4	-VS	-V Signal. The -VS should be connected to the -S to reduce the noise when "output voltage TRIM" function is in use.
5	PV	Connect to external DC voltage source for output voltage trimming, referenced to pin 10,11 (GND). Output voltage can be trimmed between 40 ~ 110% of the rated output voltage.
6	PS	Short connecting between PV (pin5) and PS (pin6) if "output voltage TRIM" function is not used.
7	PC	Connect to external DC voltage source for output current trimming, referenced output current can be trimmed between 40 ~ 110% of the rated output current. Please refer to function manual for details.
8	PO	Short connecting between PC (pin7) and PO (pin8) if output current trim function is not used.
9	DC_OK	Open collector signal, referenced to pin10,11(GND). Low when PSU turns on. The maximum sink current is 10mA and the maximum external voltage is 5.6V.
10,11	GND	These pins connect to the negative terminal (-V). Return for DC_OK Signal output.
12	G-AUX	Auxiliary voltage output ground. The signal return is isolated from the output terminals (+V & -V).
13	ON/OFF	Turns the output on and off by electrical or dry contact between pin 13 (ON/OFF) and pin 14 (12V-AUX). Short: Power ON, Open: Power OFF.
14	12V-AUX	Auxiliary voltage output, 10.8~13.2V, referenced to pin 12(G-AUX). The maximum load current is 0.1A. This output is not controlled by the "remote ON/OFF control".

Function Manual

1. "Remote ON/OFF" and "Output voltage trim" and "Output current trim" functions are not used.

- (1) The power supply unit will have no output if the shorting connector (accessory comes along with the PSU) is not assembled. It contains three shorting wires : one is from ON/OFF (pin13) to 12V-AUX (pin14), two is from PV(pin5) to PS (pin6) and the other is from PC (pin7) to PO (pin8).
- (2) Factory setting is shorted as Fig1.1

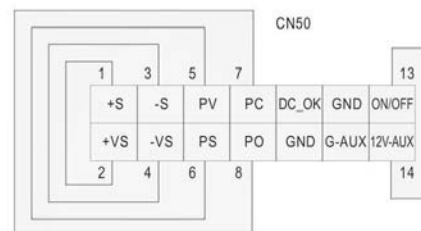
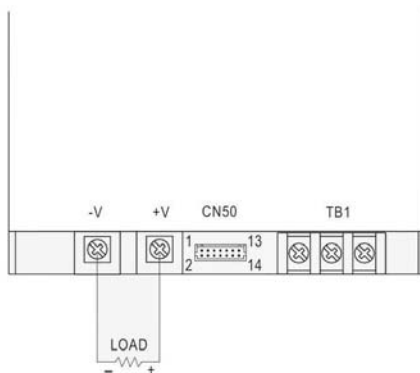
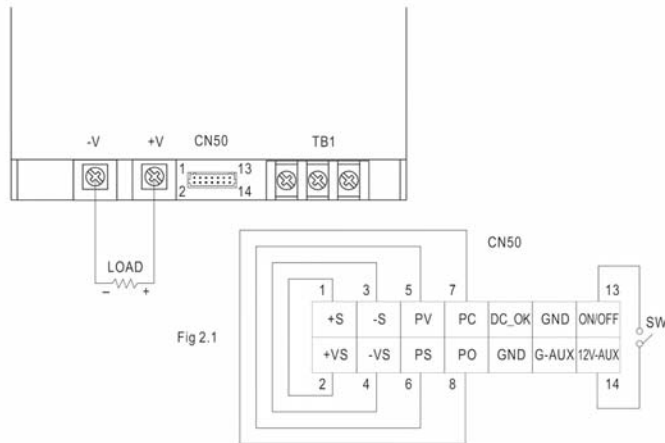

Fig 1.1 (Shorting connector)

2. Remote ON/OFF

The PSU can be turned ON/OFF by using the "Remote ON/OFF" function

Between ON/OFF(pin13) and 12V-AUX(pin14)	Output Status
SW close (Short)	PSU ON
SW open (Open)	PSU OFF



3. DC_OK signal

"DC_OK" is an open collector signal. It indicates the output status of the PSU. It can operate in two ways : One is sinking current from external TTL signal ; the other is sending out a TTL voltage signal.

3-1 Sink current :

The maximum sink current is 10mA and the maximum external voltage is 5.6V.

3-2 TTL voltage signal :

Between DC- OK(pin9) and GND(pin10&11)	Output Status
0 ~ 1V	PSU ON
3.3 ~ 5.6V	PSU OFF

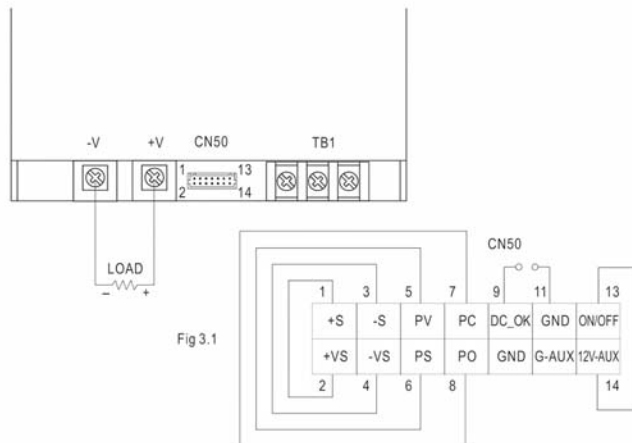

4. Remote Sense

The remote sensing compensates voltage drop on the load wiring up to 0.5V.

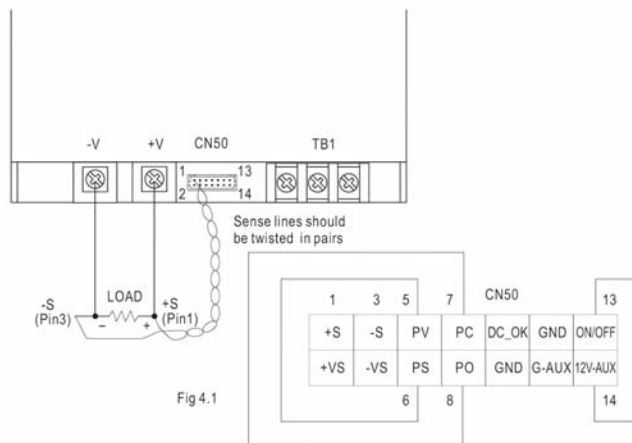

5. Output Voltage TRIM

Output voltage of RSP-750 can be trimmed between 40% ~ 110% of its rated value by the following methods :

- (1) Using an external DC source (2~5.5VDC) between "PV"(pin5) and "GND"(pin10,11) that is shown in Fig5.1

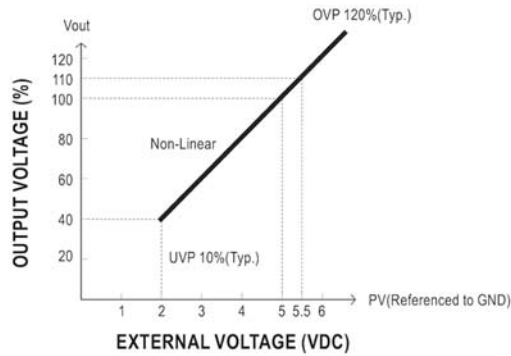

Note: External voltage < 0.5V Vo may be the UVP need to restart.

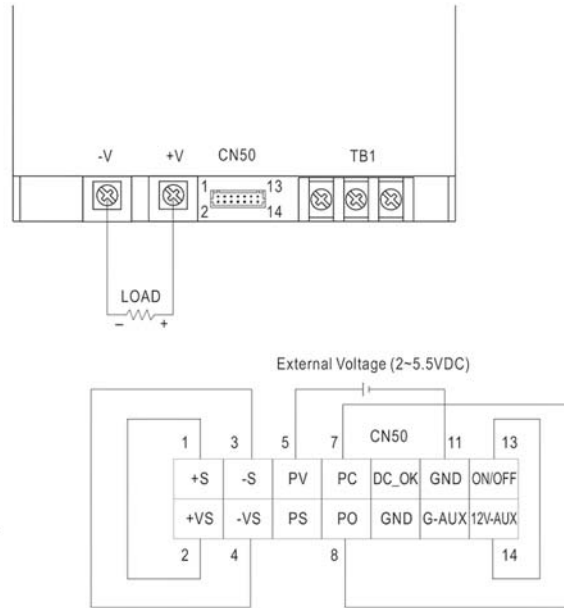

Fig 5.1

6. Output Current TRIM

Output current of RSP-750 can be trimmed between 40% ~ 110% of its rated value by the following methods :

- (1) Using external voltage source between "PC"(pin7) and "GND"(pin10,11) that is shown in Fig6.1

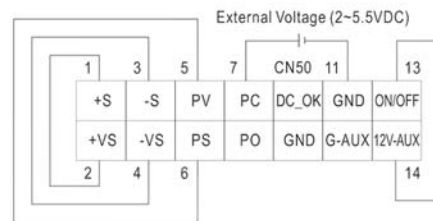
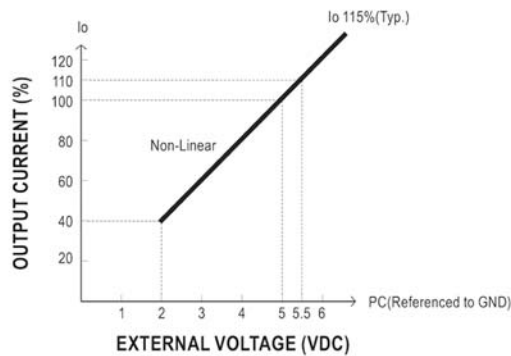

Fig 6.1